

10-12-2024

Fibre Sensing Incubator Project: Closure Report

Grant Agreement No.: 101100680
Work Package: 6
Task Item: 4
Dissemination Level: PU (Public)
Lead Partner: CSUC/RedIRIS
Document ID: GN5-1-24-AN5ROT
Authors: Chris Atherton (GÉANT), Ivana Golub (PSNC), Maria Isabel Gandía Carriedo (CSUC/RedIRIS), Pavle Vuletic (UoB/AMRES)

Abstract

The document summarises the results and key achievements of the Fibre sensing NETDEV Incubator project run as a part of the Network Development Work Package (WP6) of the GN5-1 project. Fibre sensing represents a significant opportunity for NRENs to leverage their existing fibre optic infrastructure for environmental monitoring and other applications. Technical possibilities and solutions, user community, policies around data sharing and a holistic eco-system from data gathering to harvesting was in scope of the project and its first conclusions were presented at an infoshare in December 2024.



Co-funded by
the European Union

© GÉANT Association on behalf of the GN5-1 project. The research leading to these results has received funding from the European Union's Horizon Europe research and innovation programme under Grant Agreement No. 101100680 (GN5-1).

Co-funded by the European Union. Views and opinions expressed are however those of the author(s) only and do not necessarily reflect those of the European Union. Neither the European Union nor the granting authority can be held responsible for them.

Table of Contents

Executive Summary	1
1 Introduction	2
2 Project Results	3
3 Next Steps and Future Work	6
4 Conclusions	7
References	8
Glossary	9

Table of Figures

Figure 2.1: Possible NREN roles in a national context of a proposed fibre sensing ecosystem, as explained in the Fibre Sensing Focus Group Milestone report	3
Figure 2.2: Overview of the different optical fibre sensing technologies	4
Figure 2.3: Fibre sensing data management secure research environment	5

Executive Summary

Fibre sensing represents a significant opportunity for NREs to leverage their existing fibre optic infrastructure for environmental monitoring and other applications. By using fibre optic cables as sensors, NREs can collect valuable data on a wide range of environmental and infrastructural parameters.

Preceded by the fibre sensing focus group that lasted from January until March 2024, the fibre sensing incubator project worked on defining NREN roles in the fibre sensing ecosystem and exploring the technologies behind distributed and point-based sensing. Significant effort has gone into understanding the challenges of data management, particularly the handling of nationally sensitive data generated by submarine cables.

The work of the fibre sensing incubator team continued on top of the Fibre Sensing Focus Group Milestone Report [\[FS-FG-Report\]](#), focusing on the exploration of technical solutions, data management, and the fibre sensing end-to-end ecosystem. A summary of its findings were reported at an infoshare, which was used as an opportunity to engage the wider community. The project has succeeded in defining a secure research environment and identifying key stakeholders.

As the project progresses, the focus will shift to scaling fibre sensing technology, running field tests, and ensuring the long-term sustainability of the service, as well as exploring the potential of fibre sensing across diverse geographical and application contexts.

1 Introduction

Fibre sensing is an emerging field of research with diverse applications across various disciplines. It encompasses not only the technology itself but also the applications of the data generated by this technology. Ultimately, fibre sensing is a data-generating technology, representing a significant departure from the typical research areas that National Research and Education Networks (NRENs) usually investigate. This technology aligns with the current strategy of NRENs to own and operate their own fibre optic infrastructure. As NRENs are the owners of telecoms fibre, fibre sensing enables the generation of research data using the existing infrastructure that they deploy, maintain, and manage. In essence, the goal of fibre sensing is to transform the current infrastructure into a sensor capable of detecting environmental changes at both micro and macro levels.

The fibre sensing incubator was first proposed and swiftly approved in December 2023 by the NETDEV Incubator [\[NETDEV-Inc\]](#) team of the Network Development Work Package (WP6) [\[NETDEV\]](#) of the GN5-1 project. The initial proposers were GÉANT Association, CESNET, GARR, GRENA, GRNET, NORDUnet (SUNET), NORDUnet (SIKT), and PSNC. This initial group of NRENs was later joined by HEANet and NORDUnet (DEIC) in 2024. Although this combined group could be considered the core group within the GN5-1 project focused on fibre sensing, several other NRENs expressed interest in the technology during 2024, bringing the total number of NRENs engaged in fibre sensing to 16 (as of the time of writing).

Given the growing interest in fibre sensing from the community, coupled with geopolitical tensions arising from suspected telecom and power cable cuts in the Baltic Sea and the sabotage of telecom infrastructure during the Paris Olympics, there has been a steady increase in awareness and expectations from the group working on this technology. The remainder of this report outlines the results achieved during the GN5-1 project period within the fibre sensing incubator, the resources utilised, and the next steps and future direction of the work.

2 Project Results

The group’s work continued from the focus group’s recommendations document [\[FS-FG-Report\]](#). This document defined the rationale for incorporating fibre sensing into the GÉANT project, leading to the transition from a focus group to an incubator. It also highlighted the potential roles for NRENs in the fibre sensing field as presented at [Figure 2.1](#) below. One important observation is that no single NREN can cover all the outlined roles; rather, each NREN would play a key function, potentially covering multiple roles, within the overall system deployed in each country.

The key point is that stakeholders who use the generated data must be embedded within NRENs, contributing to the overall system deployed. This approach strengthens the synergy between NRENs, their users, and stakeholders, leading to a co-created system. The primary output of this service is data, rather than the technologies themselves that generate it.

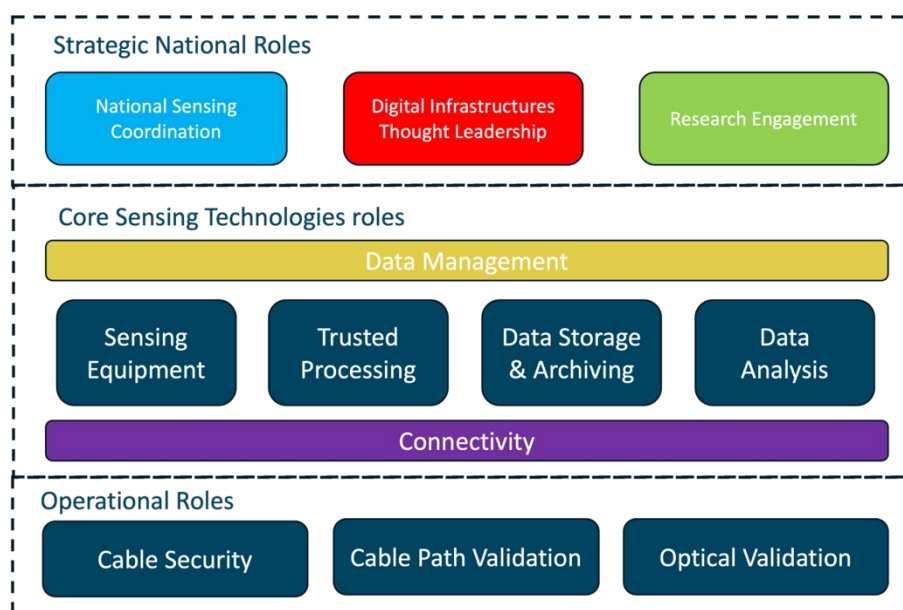

Figure 2.1: Possible NREN roles in a national context of a proposed fibre sensing ecosystem, as explained in the Fibre Sensing Focus Group Milestone report

The analysis of technical possibilities and solutions is summarised by Sikt in [Figure 2.2](#), explaining that within the field of distributed sensing there are several physical characteristics of electromagnetic radiation, with each sensing technique corresponding to one of these characteristics (such as Rayleigh backscattering, polarisation, and phase sensing).

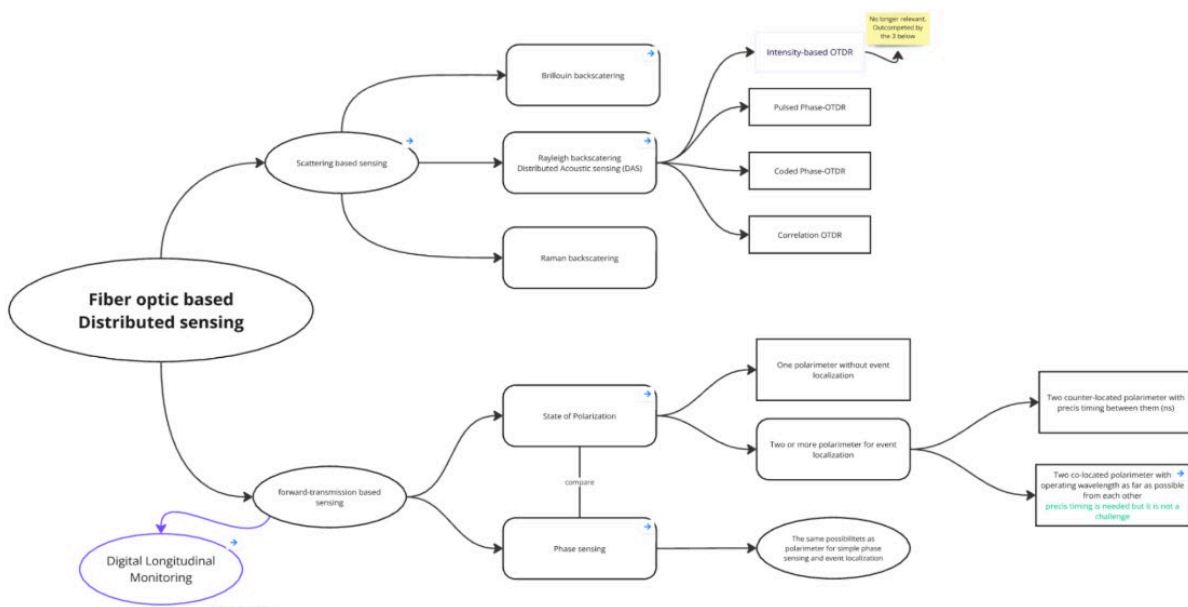

Figure 2.2: Overview of the different optical fibre sensing technologies

This technology overview was presented as an internal infoshare and its recording made available [\[KB\]](#).

In addition to the technological work, it was recognised early in the incubator’s development that understanding data management and gaining insight into the broader fibre sensing ecosystem were essential for the success of the service. Consequently, the team’s efforts centred on addressing the data management challenges inherent in the service. Specifically, the data generated by the system, particularly from submarine cables, could potentially contain nationally sensitive information. This challenge is compounded by the uncertainty surrounding what constitutes nationally sensitive data. [Figure 2.3](#), prepared by DelC, presents such a data management environment that could be typical for fibre sensing.

To address this, it is necessary to build relationships with new stakeholders, particularly national security agencies, in the regions where the system will be deployed. These agencies would also become stakeholders, providing clearance or mandates for research groups to approve the release of data. However, even national security agencies rely on research community experts to interpret this data, thereby creating a symbiotic relationship.

Efforts were made to refine and understand how data would be controlled and released within this ecosystem. Ultimately, the fibre sensing system requires a secure and trusted research environment to ensure proper handling of the data.

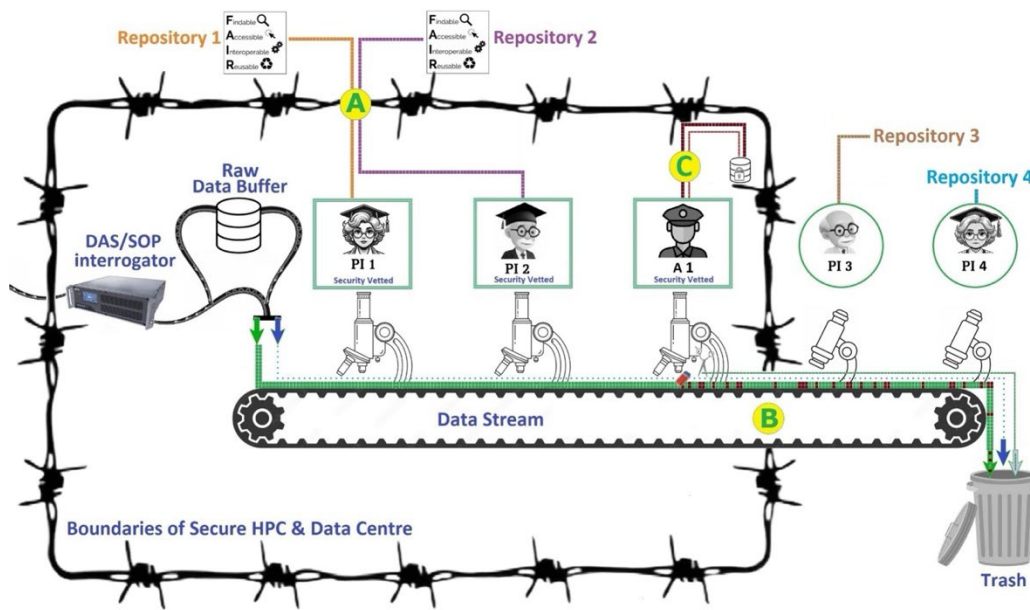

Figure 2.3: Fibre sensing data management secure research environment

Once the technologies were better understood, further work was undertaken to explore the potential users for the service. A user document was initiated, and an initial draft was created during the reporting period. However, the report has not yet been finalised and has been prioritised for completion in the next phase of the project.

An infoshare event [\[FS-IS\]](#) was held in December to:

- showcase the subject
- explain the problem being addressed
- present the proposed system, potential users, the data management and security landscape
- encourage further discussion within the community.

The event was well attended, with over 70 participants from the NREN community, research infrastructures, and research groups interested in the technology. A recording of the infoshare was made [\[FS-IS-Video\]](#), which has been viewed over 98 times at the time of writing.

While progress was made in several areas, there is still much work to be done. The work will continue including finalising the user report. However, important work was added, such as addressing data management and ecosystem issues, which were not initially anticipated when the incubator was formed. Nonetheless, substantial work remains, as detailed in [Section 4](#).

3 Next Steps and Future Work

The goal of the team is to establish a deployable fibre sensing service for the GÉANT community, to be used across the networks and infrastructure that EU NRENs operate and own. To achieve this, a number of expected outputs must be realised in order to move the concept into development. These outputs will be formalised in a set of documents covering the following areas:

1. Problem statement and objectives
2. Users
3. Benefits
4. Service description
5. Market analysis
6. Costs
7. Funding
8. Roadmap
9. Planning
10. Resources

There are several challenges that must be addressed and formalised to reach this goal, including:

- Interaction with national authorities.
- Long term sustainability for the service.
- Creating an architecture that is scalable for future fibre sensing technologies and meets the long-term sustainability requirements, but that is not cost prohibitive for NRENs to deploy.

To this end, a proposal has been accepted to transform the incubator into a sub-task within Work Package 6 of the upcoming GN5-2 project. Within this sub-task, the team will explore a range of topics and themes related to the 10 documents outlined above. These include:

- Expanding the number of NRENs involved to explore the potential of sensing over already-deployed optical fibre communication networks.
- Studying available technologies and techniques for sensing over optical fibre cables.
- Investigating sensing technologies on NREN-owned optical fibre in terrestrial areas, including lakes and fjords.
- Running field tests with scientists to monitor environmental parameters, such as understanding the causes of climate change.
- Conducting field tests with industry and governmental bodies to explore fibre sensing for early warnings in various applications, such as landslides, wildlife collisions with trains, and transport monitoring.
- Studying the ecosystem required to create a large-scale sensing network.
- Determining the number of local nodes available for trials (proofs of concept) and defining the scope of each trial.

- Validating current state-of-the-art technology and offering recommendations to other NRENs wishing to join the initiative (e.g., comparing dedicated sensing fibres versus existing links used for data transmission).

As we move forward with these plans, it is crucial to reflect on the progress made so far and the challenges that lie ahead. The following section will present our conclusions, summarising the key insights and laying the foundation for future developments in fibre sensing within the NREN community.

4 Conclusions

Fibre sensing technology has the potential to transform NREN infrastructure into a dynamic tool for monitoring environmental changes, utilising existing fibre optic networks. The concept was officially introduced in 2023 and has rapidly gained support from NRENs across Europe, with 16 networks currently involved. The project has achieved significant milestones, including the creation of a key document outlining the roles NRENs can play in the fibre sensing ecosystem, as well as detailing the technologies involved in distributed and point-based sensing.

Efforts have concentrated on addressing data management challenges, particularly regarding the national sensitivity of data generated by submarine cables, while also establishing a secure research environment. A user document is currently in development, and an infoshare event was successfully held to raise awareness of the project. However, several aspects of the work, including the finalisation of the user report, remain outstanding.

Looking ahead, the project will transition into the GN5-2 work package, where additional studies and field tests will explore the scalability of fibre sensing technology, its potential applications across various sectors, and its long-term sustainability.

References

- [FS-FG-Report]** https://wiki.geant.org/download/attachments/631443164/GN5-1_Fibre-Sensing-Focus-Group-Conclusions-and-Future-Work.pdf?version=1&modificationDate=1717668572613&api=v2
- [FS-IS]** <https://events.geant.org/event/1725/>
- [FS-IS-Video]** <https://youtu.be/BdHDBvBt9HQ?si=0E1yp8rIJEFLajgK>
- [KB]** <https://geant.box.com/s/m7nou4kdf59pue24gw76hzb56bnfwr>
- [NETDEV]** <https://wiki.geant.org/display/NETDEV>
- [NETDEV-Inc]** <https://wiki.geant.org/display/NETDEV/NETDEV+Incubator>

Glossary

GN5-1	GÉANT Network 5 Phase 1 project, part-funded from the EU's Horizon Europe research and innovation programme under Grant Agreement No. 101100680
NREN	National Research and Education Network
WP	Work Package
WP6	Work Package 6 (Network Development)